

HAPS Interposer Modules

TIPA-3100 & TIPD-3200 Data Sheet

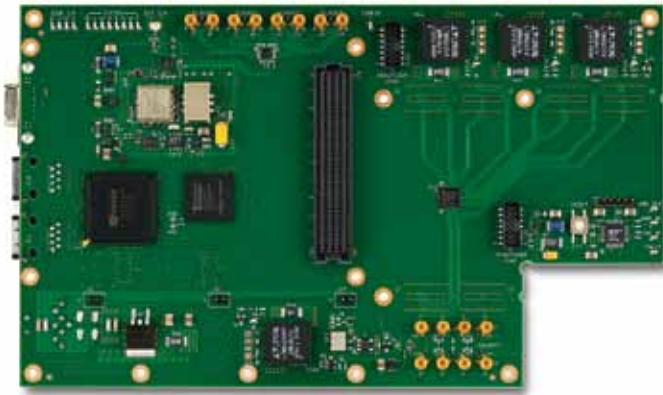

TIPA-3100 Digitizer Interposer



TIPD-3200 DAC Interposer

General Description

The HAPS® (High-performance ASIC Prototyping System) is a product family from Synopsys (www.synopsys.com) that consists of high-performance prototyping motherboards. These motherboards are ideal for prototyping complex, FPGA-based systems. The TIPA-3100 and TIPD-3200 interposer modules from Tektronix Component Solutions interface the HAPS board to Tektronix Component Solutions Digitizer or DAC modules. Depending on the specific HAPS product, up to 4 sites are available for any combination of digitizer or DAC modules and their associated interposers.

The interposers and digitizer/DAC modules are able to sustain full bandwidth to the host FPGAs through the HAPS parallel digital connectors (HapsTrak II). On the largest HAPS boards, there are four possible sites for interposers: two on the left and two on the right as you look at the module from the top. There are four interposer designs: two each for the Digitizer (TIPA-3100) and DAC (TIPD-3200), with variants for left (AD) and right (BC) board sites respectively.

Features & Benefits

- Configure HAPS with 1-4 interposers and combinations of digitizers and DAC modules
 - Enables system data rates of up to 480 Gbps and extensive digital signal processing
- Quick, easy prototyping of complex systems for signal acquisition and generation applications
 - Faster proof-of-concept and time-to-market
- Provides customer access to Tektronix digitizer and DAC technology
 - Complete packaged and validated design that speeds time-to-market
- Single-, dual- and quad-FPGA configurations provide ~4.5, 9 or 18 million gates
 - Scalable architecture with high-speed FPGA-to-FPGA busses
- Expandability via HapsTrak II standard
 - Enables use of a wide array of industry standard buses and peripherals

Applications

- Digital RF Memory (DRFM)
- SIGINT, ELINT, COMINT
- Electronic warfare system test and threat simulation
- Radar simulation
- Communications simulation

HAPS Overview

A HAPS system consists of at least one motherboard, which serves as a logic container for the FPGAs.

High quality connectors for I/Os and inter-FPGA buses are placed in a regular 70x50 mm matrix. Each FPGA is joined to a group of these connectors, with each having dedicated pins for power and clocks.

Fixed buses connect the FPGAs together and wider buses are easily created by low cost interconnect boards. Parts of the buses are joined to two pairs of HapsTrak II connectors, which can be used to expand the buses to other motherboards. Each FPGA also has a number of GPIOs.

Dedicated clock inputs on the FPGA devices are connected to global clocks. The low skew, high-speed clocks are distributed by buffers. The clocks can be driven either externally, from the FPGAs or from on-board oscillators.

Ordinary daughter cards, like memory boards and interface boards, can be placed on any connector. The size of a daughter card is strictly specified.

The dimensions of motherboards follow the same rules as for daughter cards, meaning motherboards can be placed side-by-side and connected together with standard interconnect boards. Since all HAPS motherboards have mating connectors on the bottom side, they can also be stacked together. All connectors conform to the HapsTrak II standard.

The HAPS system was specifically developed to enable faster time-to-market and greater flexibility for system designers. Tektronix Component Solutions and Synopsys are able to take a prototyping system design and implement a more integrated solution for customers who desire a smaller, lower power monolithic design in the smallest possible physical size.

Block Diagram

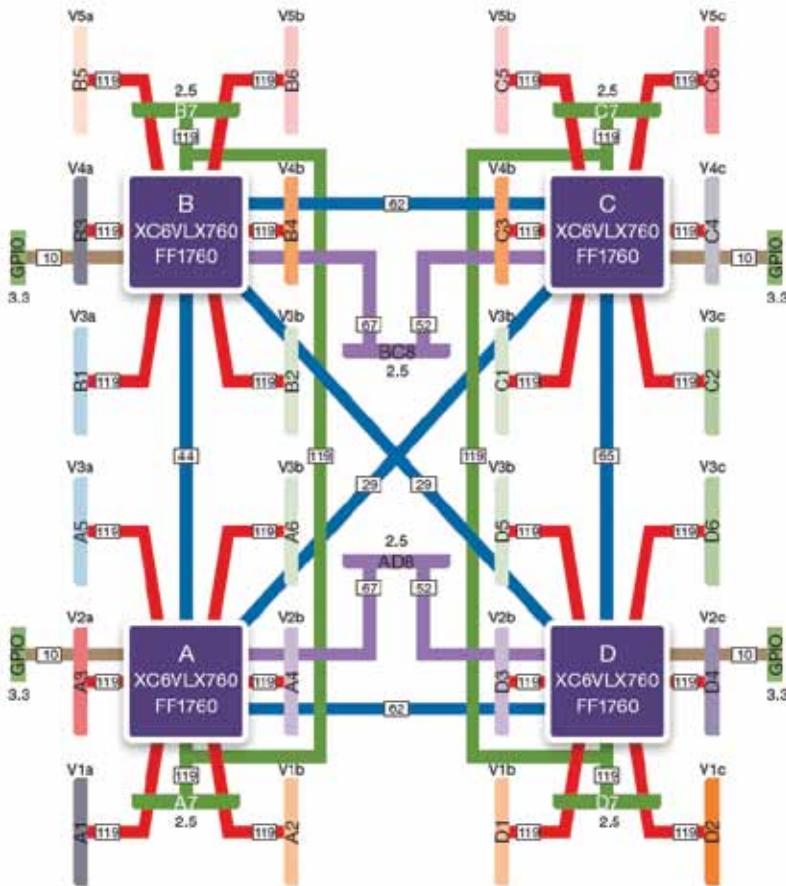

HAPS motherboard block diagram (Image courtesy of Synopsys).

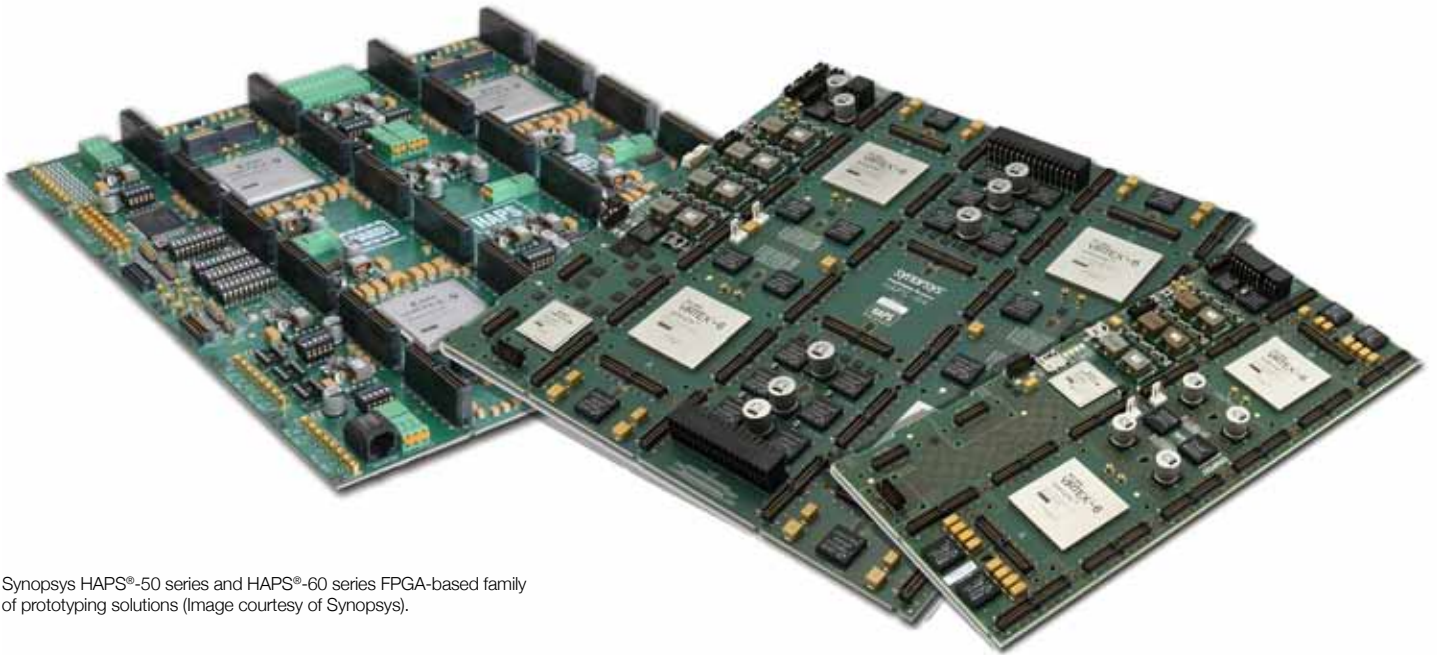

Synopsys HAPS®-50 series and HAPS®-60 series FPGA-based family of prototyping solutions (Image courtesy of Synopsys).

HAPS Board Theory of Operation

Each FPGA on the HAPS board has six dedicated HapsTrak II connectors and one shared connector, for a total of 28 connectors or 3094 I/Os on a HAPS-54 or HAPS-64 board. Each FPGA also has 135 fixed I/O line interconnects to adjacent FPGAs. The Tektronix Component Solutions

interposers mate with three of the HapsTrak II connectors on the HAPS motherboard, and routes power and the signals from the HapsTrak II connectors to the custom connectors on the TADC-1000 Digitizer and TDAC-2000 DAC modules. The interposers also allow routing of clocks between multiple digitizers and DACs, and provide calibration connectors to ensure optimal timing and cable length calibration.

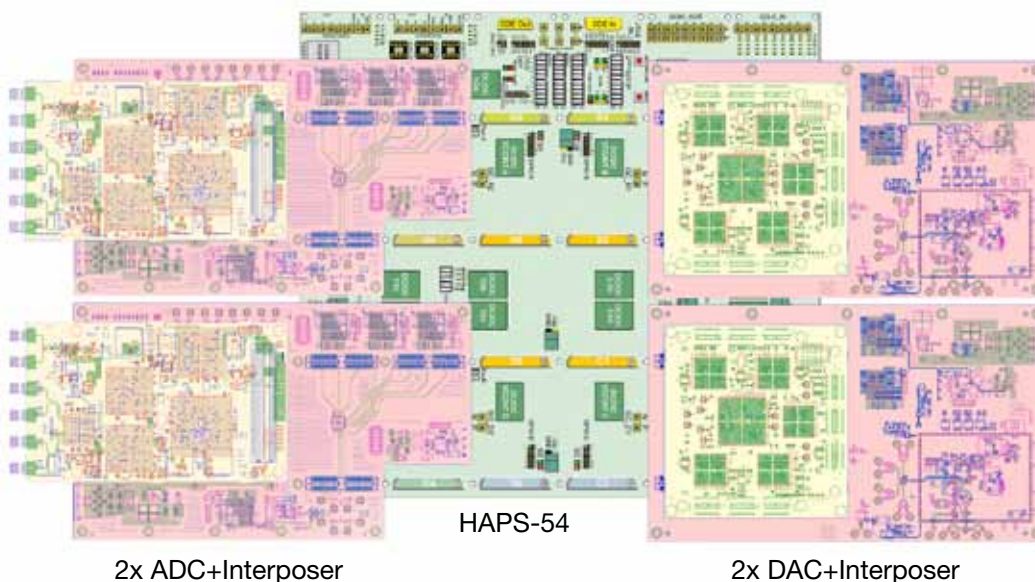

Sample stack-up showing HAPS motherboard with two digitizers and their corresponding interposers on the left, and two DACs and corresponding interposers on the right.

HAPS & Digitizer Interposer Theory of Operation

The TIPA-3100 Interposer board consists of a 5.3" x 8.5" circuit board with a 500-pin connector at one end that interfaces to a Tektronix Component Solutions TADC-1000 Digitizer module. Additionally, there is a group of three 120-pin connectors at the other end that interfaces to one FPGA on a Synopsys HAPS-51/61, HAPS-52/62, or HAPS-54/64 board. Connectivity for a 128-bit wide LVDS data bus, 10 LVDS clocks and an SPI interface are provided. A controller FPGA on the interposer provides a PCI interface from a host computer to the digitizer module, and also an SPI interface to hardware on the interposer board (clock and reference signal generation) for control of their operation.

The 128-bit data interface passes unimpeded through the interposer for maximum data integrity. A DDR (double data rate) reference clock from the digitizer is buffered and multiplied to provide 10 clocks to the HAPS FPGA for input of high speed data into various clock domains. An additional 20 unused interconnect lines are provided from the HAPS FPGA to a controller FPGA on the Interposer for future use.

Additional hardware functionality on the board includes power supplies for the digitizer from an unregulated 12 V input, high-speed clock generation and distribution (1.6 – 3.2 GHz) for multiple digitizers, and calibration signal generation and distribution to multiple digitizers. These calibration signals, when used with matched-length cables, are intended to synchronize operation of up to four digitizers for simultaneous signal acquisition.

Board Outline

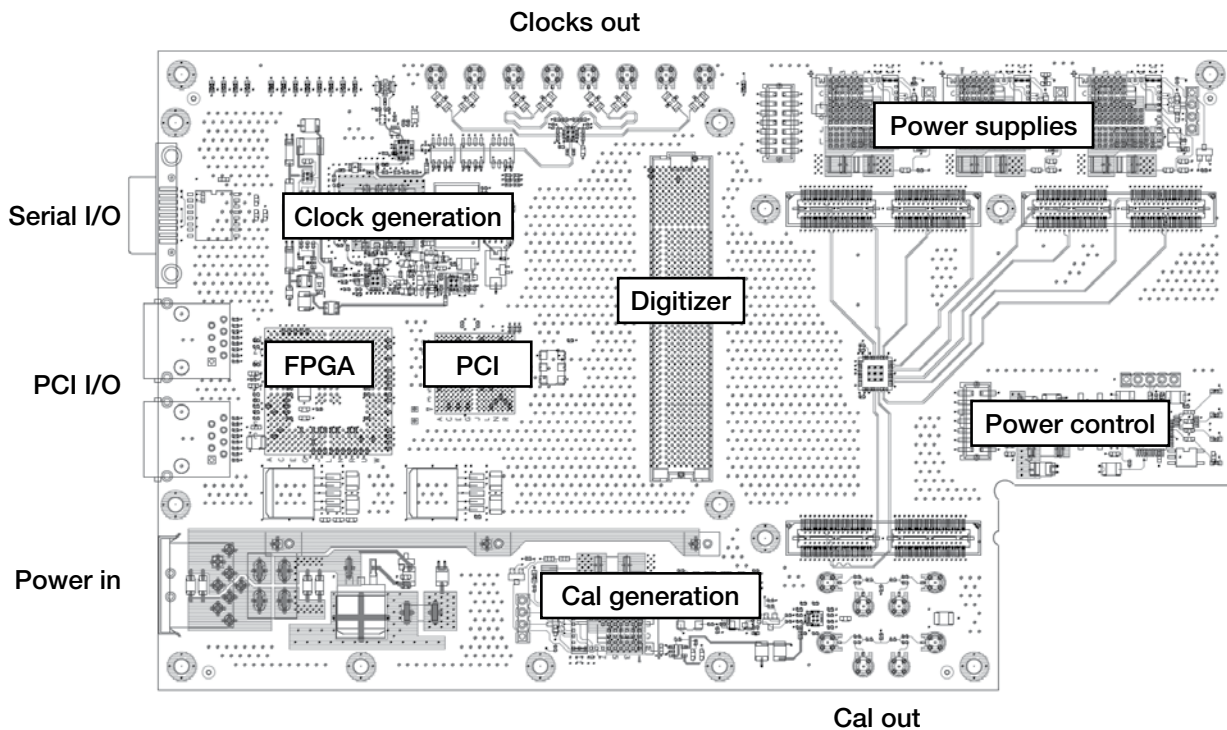

TIPA-3100 board outline with major components.

Block Diagram

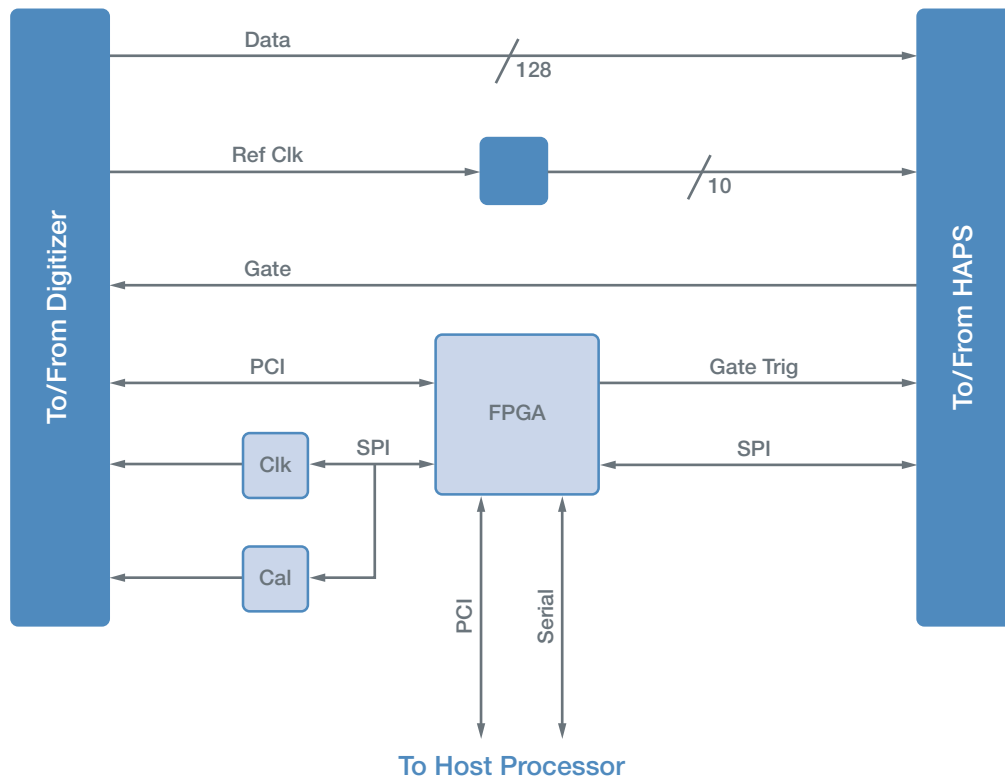

HAPS & TADC-1000 Digitizer block diagram.

TIPA-3100 Electrical Specifications

Data/clock interface

- 128-bit LVDS bus supports data rates to 800 Mbps per line (102 Gbps aggregate rate)
- Supports one or two channel operation for the TADC-1000 Digitizer

Clock generation

- 1.6 – 3.2 GHz frequency range
- ± 160 kHz fine frequency tuning (min.) at 20 Hz resolution
- RMS jitter < 1 ps
- Four differential outputs, skew < 6 ps

Calibration signal generation

- 500 MHz low distortion sine wave
- Step pulse with 700 ps rise-time
- Four differential outputs, AC coupled

TIPA-3100 Mechanical Information

Connectors

- One Samtec SEAF-50-05.0-S-10 500-pin connector (digitizer interface)
- Three Samtec QSH-060-01-LDAK 120-pin connectors (HAPS interface)
- 16 SMP coax connectors for clock and calibration output to TADC-1000 digitizers
- One D-sub 9-pin serial I/O connector
- Two RJ45 female connectors for serial PCI transmit and receive
- Two 2x7 2 mm square pin JTAG headers for interposer and digitizer FPGA programming
- One 1x5 0.1" square pin header for power supply programming
- Three 1x2 0.1" square pin headers for 12 V cooling fans
- One 8-pin power supply connector

Board outline

- 5.35" x 9.00" x 0.10" (13.6 x 22.7 x 0.3 cm) board with 1.72" x 1.97" (4.4 x 5.0 cm) cut-out
- Four 0.125" (0.32 cm) diameter mounting holes for digitizer card
- Four 0.125" (0.32 cm) diameter mounting holes for fan bracket
- Six 0.125" (0.32 cm) diameter mounting holes for HAPS board

HAPS & DAC Interposer Theory of Operation

The Tektronix Component Solutions TIPD-3200 DAC Interposer board consists of a 5.3" x 9" circuit board with three 180-pin connectors at one end that interface to a TDAC-2000 DAC module. Additionally, there are a group of four 120-pin connectors on the back side that interface to one FPGA on a Synopsys HAPS-51/61, HAPS-52/62, or HAPS-54/64 board. Connectivity for a 320-bit wide CMOS data bus, six LVDS clocks, and an SPI interface are provided.

The 320-bit data interface passes unimpeded through the interposer for maximum data integrity. A DDR (double data rate) reference clock from the DAC board is buffered and distributed to provide six clocks to the HAPS FPGA for output of high-speed data. Additional hardware functionality included on the board includes power supplies for the DAC from an unregulated 12 V input and high-speed clock generation and distribution (6 – 12 GHz).

TIPD-3200 Electrical Specifications

Data/clock interface

- 320-bit CMOS bus supports data rates to 375 Mbps per line (120 Gbps aggregate rate)
- Clocks are supplied to the HAPS FPGA at up to 187.5 MHz
- A start-of-pattern indicator is provided from the HAPS FPGA for the first word transferred to the DAC
- DAC output is enabled by providing a differential ECL rising edge to the DAC coax inputs labeled CLK-EN

Clock generation

- 6.0 – 12.0 GHz frequency range
- RMS jitter < 500 fs
- One differential output at full rate (labeled CLK TO DAC)
- One differential output at half rate (labeled CLK TO DIG)
- One single-ended input (labeled EXT_ADC_CLK)

Board Outline

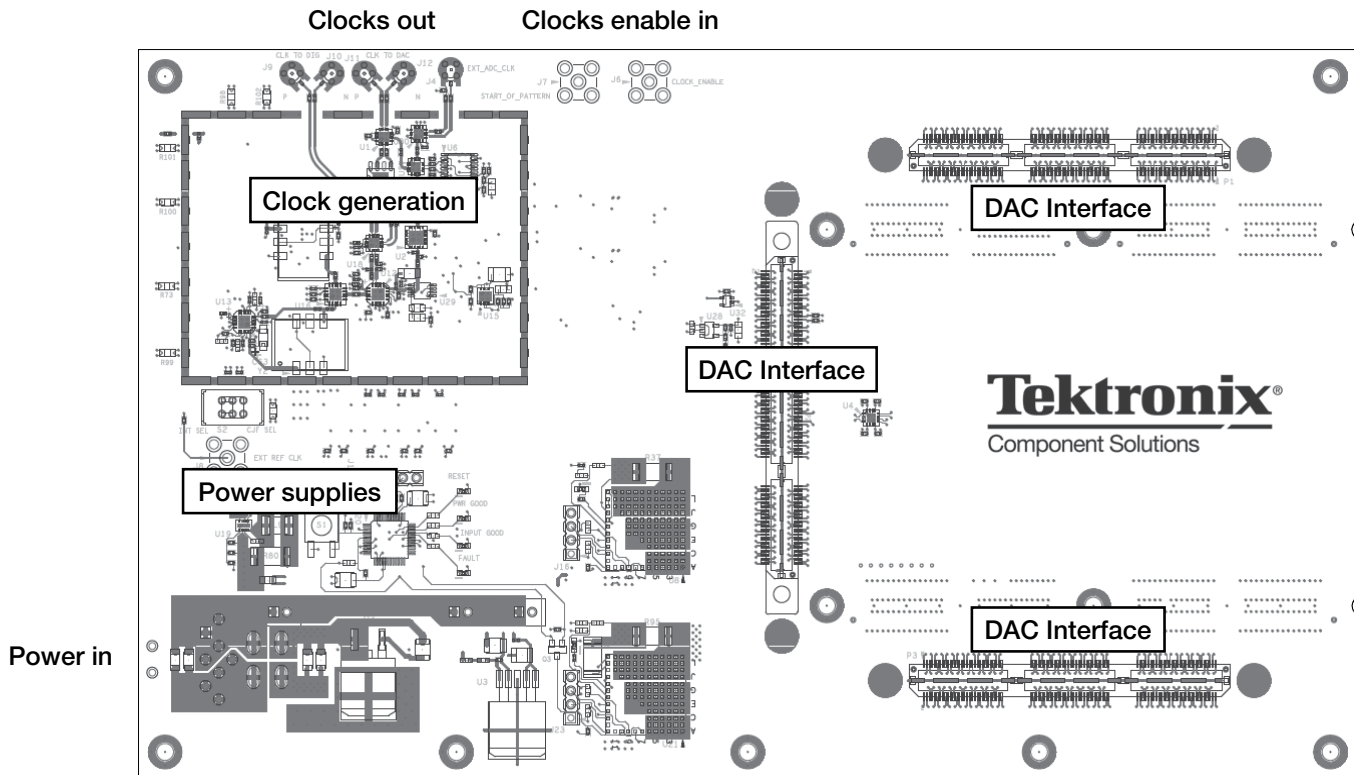

TIPD-3200 board outline with major components.

TIPD-3200 Mechanical Information

Connectors

- Three Samtec QTH-090-01-LDAK 180-pin connectors (TDAC-2000 DAC interface)
- Four Samtec QSH-060-01-LDAK 120-pin connectors (HAPS interface)
- Five SMP coax connectors for clocks
- Three SMA connectors for START_OF_PATTERN output, CLOCK_ENABLE output, and EXT_REF_CLK input
- One 1x5 0.1" square pin header for power supply programming

- Three 1x2 0.1" square pin headers for 12 V cooling fans
- One 8-pin power supply connector

Board outline

- 5.35" x 9.00" x 0.10" (13.6 x 22.9 x 0.3 cm) board
- Four 0.125" (0.32 cm) diameter mounting holes for DAC card
- Four 0.125" (0.32 cm) diameter mounting holes for fan bracket
- Six 0.125" (0.32 cm) diameter mounting holes for HAPS board

About Tektronix Component Solutions

With four decades of expertise, a talented in-house engineering team, a lean US-based manufacturing facility, advanced test capabilities and DSCC-suitable labs, Tektronix Component Solutions brings performance, reliability and quality to component design, assembly and test.

Originally created in 1970 as the Hybrid Components Organization within Tektronix, the group was formed to supply high-performance components for Tektronix high-speed measurement equipment, a charter we continue to fulfill today.

In 1994, our organization was spun out as a joint venture between Maxim and Tektronix. As Maxtek, we began to apply our expertise in the design, assembly and test of demanding microelectronics for customers in a variety of industries.

Reacquired by Tektronix in 2000 and renamed Tektronix Component Solutions in 2010, our organization continues to provide a full range of design, assembly and test services to those requiring components for demanding applications.

We are headquartered in Beaverton, Oregon, with additional sites in Orlando, Florida and Phoenix, Arizona.

For price, delivery and ordering information contact Tektronix Component Solutions directly at 1 (800)-462-9835 or email us at components@tektronix.com. For more information visit us at component-solutions.tektronix.com.



Headquarters:

2905 SW Hocken Avenue
Beaverton, Oregon 97005

Component Test Labs:

6120 Hanging Moss Road
Orlando, Florida 32807

2320 West Peoria Avenue, D133
Phoenix, Arizona 85029



Copyright © 2011, Tektronix Component Solutions. All rights reserved. Information in this publication supersedes that in all previously published material. Specification and price change privileges reserved. TEKTRONIX COMPONENT SOLUTIONS is a registered trademark of Tektronix Component Solutions. HAPS imagery and information are courtesy, and registered trademark, of Synopsys. All other trade names referenced are the service marks, trademarks, or registered trademarks of their respective companies. 00012-0511-1